

Connecting Rod Bolt

Connecting Rod Cap Bolts

Step 1	26 ft. lbs.
--------	-------------

Step 2	51 ft. lbs.
--------	-------------

Step 3	73 ft. lbs.
--------	-------------

Crankshaft Main Bearing

REMOVAL

1. Remove engine from vehicle and place on a stand.
 2. Remove oil pan and suction tube.
 3. Remove the crankshaft rear seal retainer.
 4. Remove the front gear housing.
-

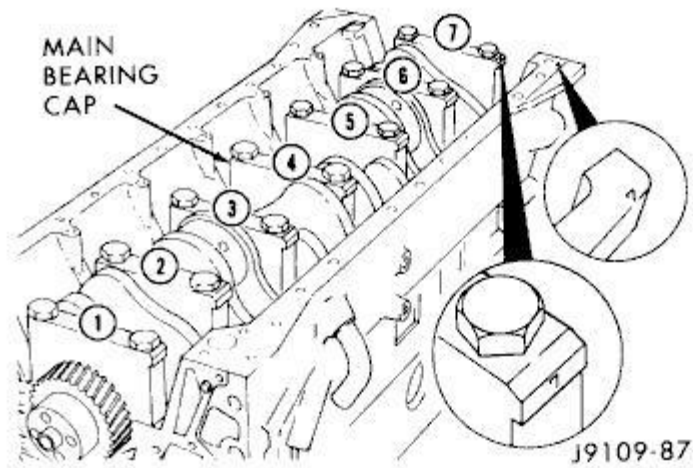

Fig. 178 Numbering Main Bearing Caps

Zoom

Sized for Print

Fig. 178

5. The main bearing caps should be numbered. If they are not, be sure to mark them, beginning with number one at the front and ending with number seven at the rear (Fig. 178). **CAUTION:** DO NOT pry on the main caps to free them from the cylinder block.

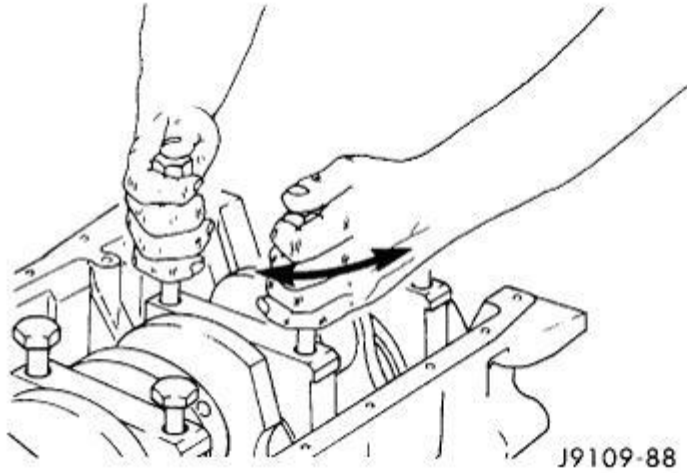

Fig. 179 Main Bearing Cap Removal

1 - MAIN BEARING CAP

Zoom

Sized for Print

Fig. 179

6. Use two of the main bearing cap bolts to wiggle the main cap loose (Fig. 179), being careful not to damage the bolt threads. Remove all caps in the same manner.
WARNING: USE A HOIST TO AVOID INJURY.
-

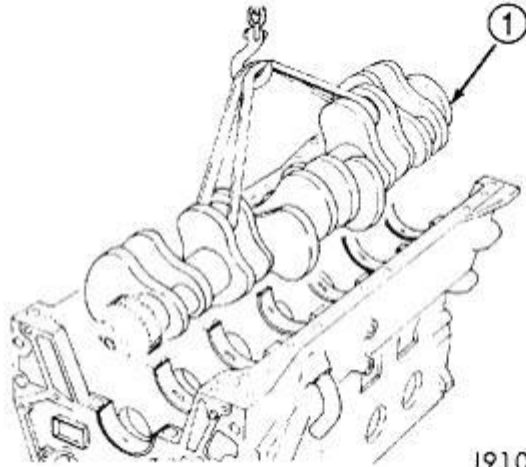

J9109-89

Fig. 180 Lifting Crankshaft Out of Cylinder Block
1 - CRANKSHAFT

Zoom

Sized for Print

Fig. 183

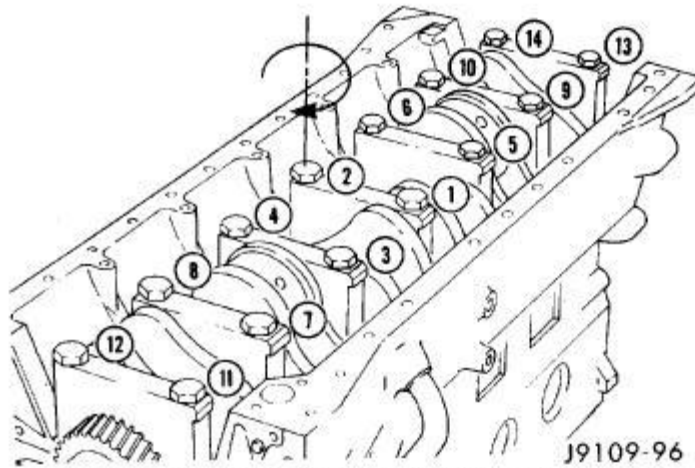
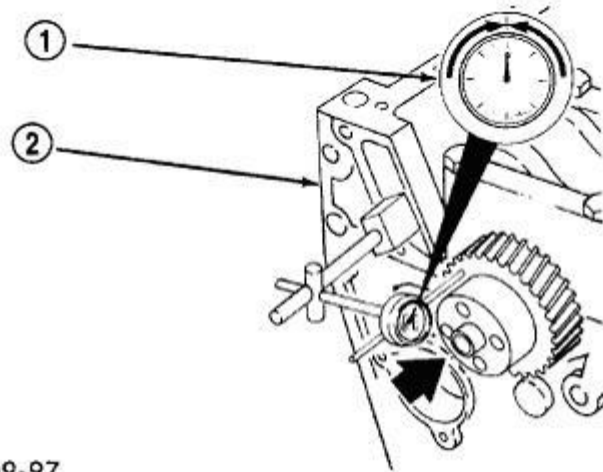

Fig. 183 Crankshaft Main Bearing Bolt Torque Sequence

-
13. Tighten the bolts in the sequence shown in (Fig. 183) using the following steps:
 - STEP 1-Torque all bolts in sequence to **60 Nm (44 ft. lbs.)** torque.
 - STEP 2-Torque all bolts in sequence to **119 Nm (88 ft. lbs.)** torque.
 - STEP 3-Torque all bolts in sequence to **176 Nm (129 ft. lbs.)** torque.

 14. Turn the crankshaft to determine that it will rotate freely all 360°. Check the main bearing cap installations and/or the bearing sizes if the shaft does not turn easily.
-



J9109-97

Fig. 184 Measuring Crankshaft End Play

- 1 - DIAL INDICATOR
- 2 - CYLINDER BLOCK

Zoom

Sized for Print

Fig. 184

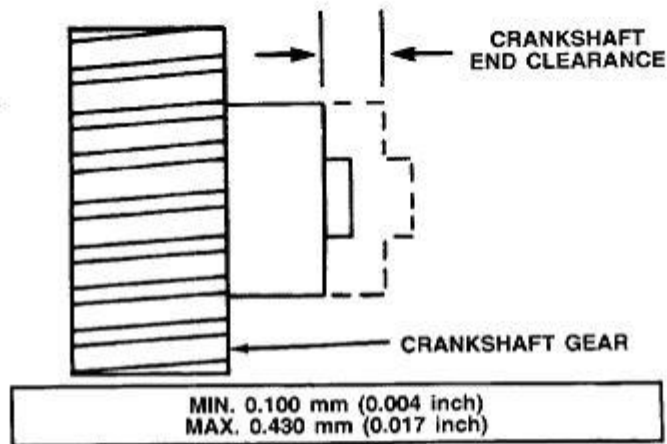

J9409-120

Fig. 185 Crankshaft End Clearance
CRANKSHAFT END PLAY SPECIFICATIONS

MIN	0.100 mm (0.004 in.)
MAX	0.430 mm (0.017 in.)

Zoom

Sized for Print

Fig. 185

15. Verify crankshaft end play: Push the crankshaft towards one end of its thrust and place a dial indicator as shown in (Fig. 184). Zero the indicator needle and push the crankshaft towards the other end of its thrust and record the crankshaft end clearance (Fig. 185).
16. Install the front gear housing.
17. Install the crankshaft rear oil seal retainer.
18. Install the oil pan and suction tube.
19. Install engine into vehicle.

Cylinder Head

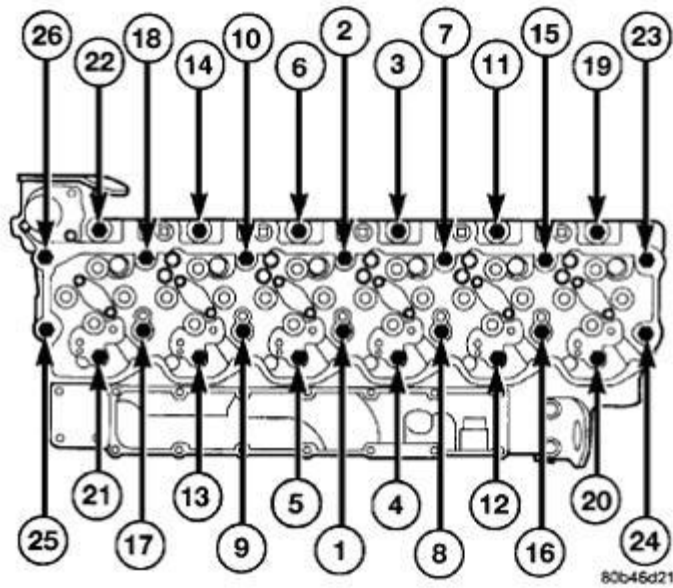

Fig. 30 Cylinder Head Bolt Torque Sequence

Zoom

Sized for Print

Using the sequence shown, tighten bolts in the following steps:

1. Torque bolts to **90 Nm (66 ft. lbs.) (All Capscrews)**
2. Recheck to **90 Nm (66 ft. lbs.) (All Capscrews)**
3. Torque bolts to **120 Nm (90 ft. lbs.) (Long Capscrews Only)**
4. Re-check all bolts to **120 Nm (120 ft. lbs.) (Long Capscrews Only)**
5. Tighten all bolts an additional **1/4 turn (90 °) (All Capscrews)**